

Dynatrol®

CL-10GSS

The Dynatrol® CL-10GSS Level Detector for bulk solids is intended for high-, intermediate- or low-point level detection on extremely light weight applications that are difficult to measure or get a reading. You can use Dynatrol® Level Detectors for measurement and control on a variety of storage tanks, bins and silos. Built in the USA for over 60 years, Dynatrol® Level Detectors are solidly constructed and designed as a long-lasting, reliable solution for a variety of applications.

ADVANTAGES

Dynatrol® level detection switches operate where other types of controls may experience failure, and perform with consistent results on many difficult product applications. All the level detector components are constructed for a long operating life and require no field adjustments. Dynatrol® Level Detectors can be modified for special level detection applications such as temperatures greater than 600°F, cryogenic temperatures, chemical corrosion, and media requiring special coatings. Let Dynatrol® provide a worry-free solution for you today!



SPECIFICATIONS

DYNATROL® CL-10GSS Level Detector

- EXPLOSION PROOF: CSA NRTL/C approved for Class I, Group C & D; Class II, Groups E, F & G; Class III
- TEMPERATURE RATING: 300°F
(consult factory for higher ratings)
- PRESSURE RATING: 1000 PSIG @ 100°F
(consult factory for higher ratings)
- PRESSURE CONNECTION: 3/4-inch NPT
- CONDUIT CONNECTION: 1/2-inch NPT
- TYPICAL DENSITY RANGE: < 5 lbs/ft³

PRINCIPLE OF OPERATION

The Dynatrol® CL-10GSS Level Detector consists of a paddle-style probe which is installed through the wall of the bin or duct at the point of desired level detection. When the probe is uncovered, the paddle is free to vibrate and produce an output signal. This signal operates a relay indicating the paddle is uncovered and a low level exists. A dampening of the oscillation occurs when the paddle is covered and the loss of signal de-energizes the relay indicating a high level exists.

The On/Off signal from the Dynatrol® Detector operates a SPDT relay in the EC-501A(G) Control Unit. The contacts of this relay can be used to actuate level alarms, indicator lights or process control equipment.

TOMATION PRODUCTS, INC.
3030 MAXROY STREET • HOUSTON, TEXAS 77008-6294
PH: (800) 231-2062 • FAX: (713) 869-7332
WWW.DYNATROLUSA.COM • SALES@DYNATROLUSA.COM

Dynatrol® Level Detector Information

CL-10GSS

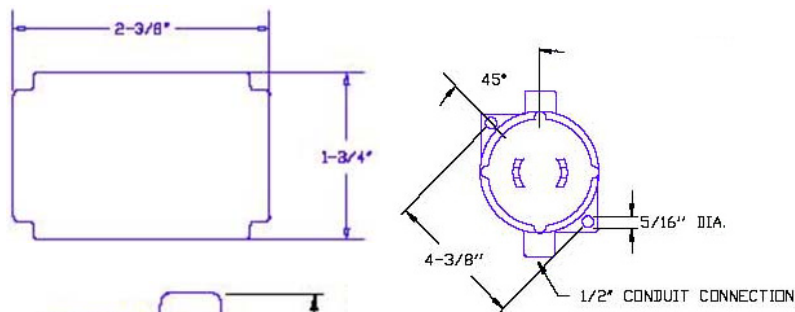
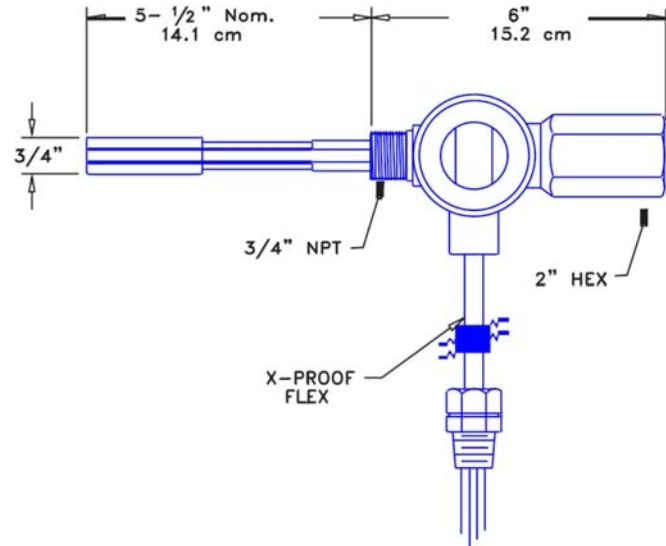
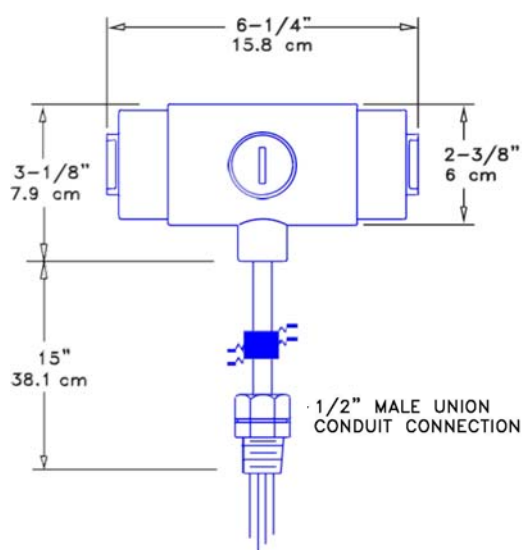

EC-501A(G)



SPECIFICATIONS

EC-501A Control Unit

- EXPLOSION PROOF: CSA NRTL/C approved for Class I, Group C & D; Class II, Group E, F & G; Class III
- VOLTAGE SUPPLY (Nom): 120v—50-60Hz
- POWER CONSUMPTION: 5 VA
- TEMPERATURE RATING: 125°F max
- CONTACTS: SPDT 2A @ 120 VAC (Non-Inductive)
- Also available in 240 VAC and 24 VDC

