

Dynatrol®

Sealed & Suspended

The Dynatrol® Sealed & Suspended Level Detector for bulk solids is intended for high-point level detection on bulk solids. For problem applications, such as those associated with angle-of-repose, this configuration provides reliable operation in hard to reach locations. Built in the USA for over 60 years, Dynatrol® Level Detectors are solidly constructed and designed as a long-lasting, reliable solution for a variety of your level detection needs.

ADVANTAGES

Dynatrol® level detection switches operate where other types of controls may experience failure, and perform with consistent results on many difficult product applications. All the level detector components are constructed for a long operating life and require no field adjustments. Dynatrol® Level Detectors can be modified for special level detection applications such as temperatures greater than 600°F, cryogenic temperatures, chemical corrosion, and media requiring special coatings. Let Dynatrol® provide a worry-free solution for you today!



SPECIFICATIONS

Dynatrol® CL-10DJ S&S Level Detector

- EXPLOSION PROOF: CSA NRTL/C approved for Class I, Group C & D; Class II, Groups E, F & G; Class III
- TEMPERATURE RATING: 350°F
(consult factory for higher ratings)
- PRESSURE CONNECTION: 3/4-inch NPT
- CONDUIT CONNECTION: 1/2-inch NPT
- MATERIAL: Stainless Steel
- TYPICAL DENSITY RANGE: 15-60 lbs/ft³

PRINCIPLE OF OPERATION

The Dynatrol® Sealed & Suspended Level Detector consists of a rod-style probe which is suspended to the desired point of level detection. When the probe is uncovered the rod is free to vibrate and produce an output signal. This signal operates a relay indicating the rod is uncovered and a low level exists. A dampening of the oscillation occurs when the rod is covered and the loss of signal de-energizes the relay indicating a high level exists.

The On/Off signal from the Dynatrol® Detector operates a SPDT relay in the EC-501A Control Unit. The relay's contacts can be used to actuate alarms, indicator lights or process control equipment.

AUTOMATION PRODUCTS, INC.
3030 MAXROY STREET • HOUSTON, TEXAS 77008-6294
PH: (800) 231-2062 • FAX: (713) 869-7332
WWW.DYNATROLUSA.COM • SALES@DYNATROLUSA.COM

Dynatrol® Level Detector Information

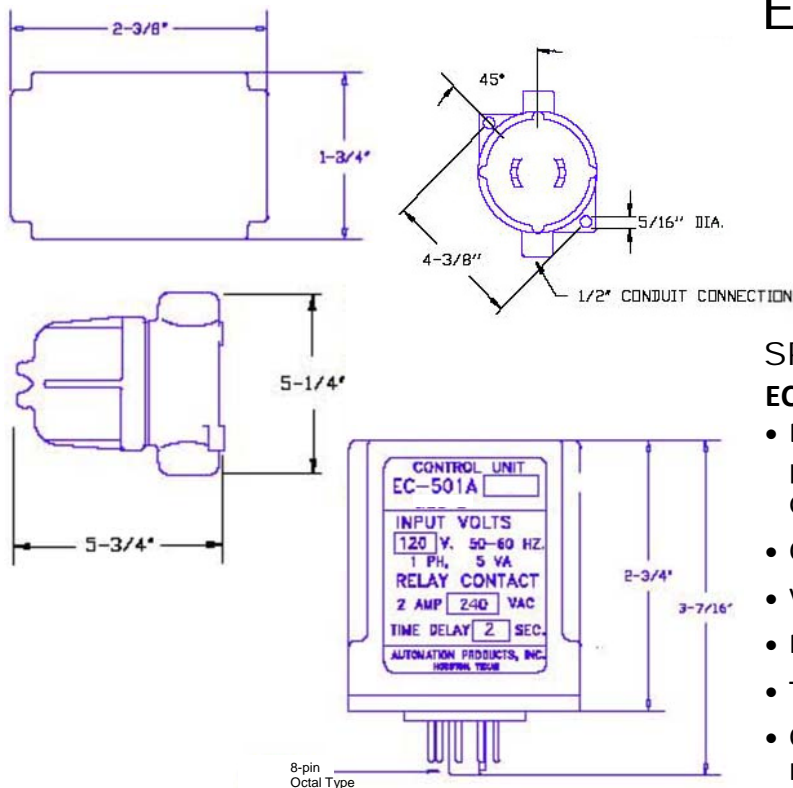
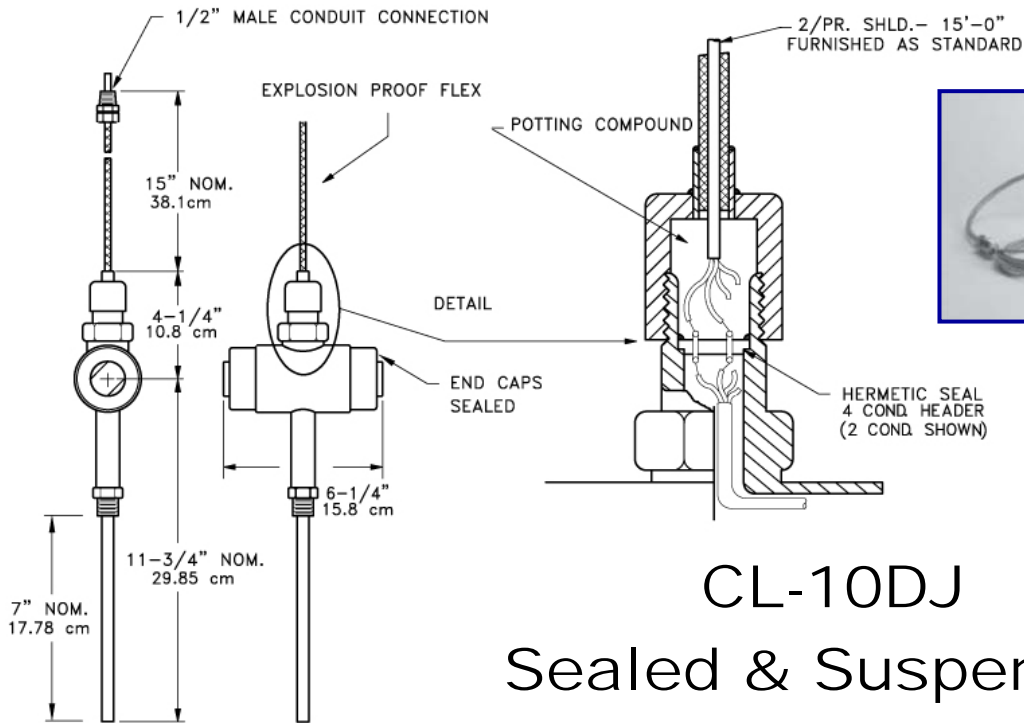

EC-501A



SPECIFICATIONS

EC-501A Control Unit

- EXPLOSION PROOF: CSA NRTL/C approved for Class I, Group C & D; Class II, Groups E, F & G; Class III
- CIRCUITRY: Solid State
- VOLTAGE SUPPLY (Nom): 120v—50-60Hz
- POWER CONSUMPTION: 5 VA
- TEMPERATURE RATING: 125°F max
- CONTACTS: SPDT 2A @ 120 VAC (Non-Inductive)
- Also available in 240 VAC and 24 VDC