

Dynatrol®

Viscosity Systems

Dynatrol® Viscosity Systems provide continuous measurement for both Newtonian and Non-Newtonian products at on-line process conditions and on a wide variety of applications. Dynatrol® Viscosity Detectors install directly into process lines or vessels for immediate results and not need sampling or laboratory analysis. Typical applications include:

- ASPHALT
- FILLED ASPHALT
- RESINS
- PETROCHEMICALS
- CRUDE OIL / BLENDS
- FUEL OIL
- FOOD
- PAINTS
- ADHESIVES
- COATINGS
- INKS
- OILS
- PAPER
- COSMETICS
- POLYMERS
- LATEX
- CERAMIC/METALLIC SLURRY
- HOT THERMOPLASTICS
- CHEMICAL REACTIONS WITH A KILL POINT
- ...and much more!

PRINCIPLE OF OPERATION

Dynatrol® Viscosity Detectors utilize unique vibratory principles. The vibrating detector rod is immersed in process media and the drive coil is electrically excited by the pulsating current which drives the probe into mechanical vibration. The vibration becomes a function of the viscosity of the media contained in the unit. If the viscosity of the media is increased, the dampening effect on the probe increases and if the viscosity decreases the dampening decreases.

The vibration is sensed in the pick-up end, which consists of an armature and coil arrangement similar to the driver end. The AC voltage is in the pick-up coil. This output from the pick-up is a function of the viscosity process media. The output signal from the Dynatrol® Viscosity Detect is fed into the solid-state converter where it is converted into a 4-20 MADC signal. The converter also contains a power supply that provides regulated power to the Dynatrol® Viscosity Detector.

ADVANTAGES

Easily Installed - Rugged - Accurate

Dynatrol® Viscosity Detectors are available in stainless steel and other corrosion-resistant materials. The detectors are designed without recesses, packing or wearing parts. The unit achieves exceptional accuracy and is rugged enough to withstand harsh environments. With no moving parts, it is virtually wear-free, ensuring a long operating life.



AUTOMATION PRODUCTS, INC.
3030 MAXROY STREET • HOUSTON, TEXAS 77008-6294
PH: (800) 231-2062 • FAX: (713) 869-7332
WWW.DYNATROLUSA.COM • INFO@DYNATROLUSA.COM

Dynatrol® Viscosity Detector Information

| <u>Model</u> | <u>Range (in cps)</u> | <u>Probe Length (nominal)</u> |
|--------------|-----------------------|-------------------------------|
| CL-10DV-1 | 0.1 - 10 | 9.5" |
| CL-10DV-2 | 1 - 100 | 8.25" |
| CL-10DV-3 | 10 - 1,000 | 7.5" |
| CL-10DV-4 | 100 - 10,000 | 6" |
| CL-10DV-5 | 1,000 - 100,000 | 4.25" |

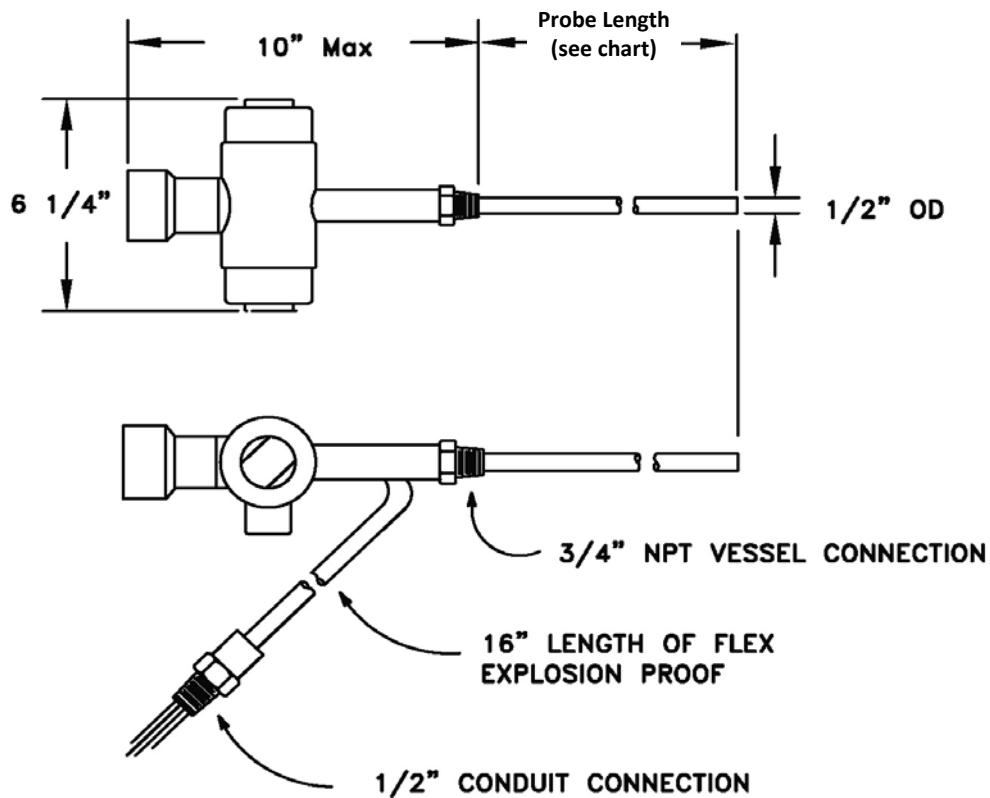

SPECIFICATIONS

DYNATROL® Viscosity Detectors

- PRESSURE RATINGS: 1000 and 1480 PSI (*consult factory for higher ratings*)
- TEMPERATURE RATING: 300°F and 500°F (*consult factory for higher ratings*)
- VISCOSITY RANGES: Up to 100,000 Centipoise
- HOUSING: Rugged, Sealed, All-Weather, Explosion proof
- PROCESS CONNECTIONS AVAILABLE: Threaded, Flanged or CIP
- STANDARD CONSTRUCTION: Stainless Steel or Hastelloy (*consult factory for other materials*)
- CSA NRTL/C Approved for Class 1, Group D, Division 1